

Electric Range Owner's Manual

Model CST 6512

Model CSTC 7512 (Convection)

Smoothtop Range

with Self-Cleaning Oven

**Please Read Manual Before
Operating Range**

- **Safety**
- **Installation**
- **Use**

Important

Save for local electrical inspector's use.

Installer

Leave this manual and other literature with consumer for future use.

Customer

Keep these instructions for future reference. If appliance changes ownership, be sure this manual accompanies range.

Contents

Important Safety Information	3
Installation	6
Using a Smoothtop	11
Using the Surface Elements	12
Utensil Recommendations	13
Electronic Oven Control and Switches	14
Display and Features	15
Service Tones	14
Setting the Clock and Timer	16
Adjusting Factory Set Baking Temperature	16
Oven Cooking Methods	17
Baking & Broiling	18
Self-Clean	22
Cooking Guide	24
User Maintenance	28
Cleaning	29
Cleaning the Smoothtop Range	30
Before Calling for Service	31
Warranty	32

Parts and Accessories

Purchase replacement parts and additional accessories (e.g., oven racks, cooktop modules) over the phone. To order accessories for your Caloric Sales Co. L.P. product, call 1-800-843-0304 inside U.S.A. or 319-622-5511 outside U.S.A.

Service

Keep a copy of sales receipt for future reference or in case warranty service is required. Any questions or to locate an authorized servicer, call 1-800-NAT-LSVC (1-800-628-5782) inside U.S.A. 319-622-5511 outside U.S.A. Warranty service must be performed by an authorized servicer. Caloric also recommends contacting an authorized servicer if service is required after warranty expires.

What You Need to Know about Safety Instructions

Warning and Important Safety Instructions appearing in this manual are not meant to cover all possible conditions and situations that may occur. Common sense, caution, and care must be exercised when installing, maintaining, or operating range.

Always contact your dealer, distributor, service agent, or manufacturer about problems or conditions you do not understand.

Model Identification

Complete enclosed registration card and promptly return. If registration card is missing, call Consumer Affairs Department at 1-800-843-0304 inside U.S.A. 319-622-5511 outside U.S.A. When contacting Caloric Sales Co. L.P., provide product information located on rating plate. Rating plate is located on the oven frame. Record the following:

Model Number: _____
Manufacturing Number: _____
Serial or S/N Number: _____
Date of purchase: _____
Dealer's name and address: _____

Asure™ Extended Service Plan

Caloric Sales Co. L.P. offers long-term service protection for this new range. Asure™ Extended Service Plan is specially designed to supplement Caloric's strong warranty. This plan covers parts, labor, and travel charges. Call 1-800-528-2682 for information.

Recognize Safety Symbols, Words, Labels



DANGER—Immediate hazards which **WILL** result in severe personal injury or death.



WARNING—Hazards or unsafe practices which **COULD** result in severe personal injury or death.



CAUTION—Hazards or unsafe practices which **COULD** result in minor personal injury or product or property damage.

IMPORTANT SAFETY INFORMATION

WARNING

To reduce the risk of the appliance tipping, it must be secured by a properly installed anti-tip bracket(s). To make sure bracket has been installed properly, remove the storage drawer or panel and look under the range with a flashlight. Bracket(s) must be engaged in the rear corner of the range.



- ALL RANGES CAN TIP
- INJURY TO PERSONS COULD RESULT



- INSTALL ANTI-TIP BRACKET(S) PACKED WITH RANGE
- SEE INSTALLATION INSTRUCTIONS

CAUTION

DO NOT TOUCH SURFACE UNITS OR AREAS NEAR UNITS—Surface units may be hot though they are dark in color. Areas near surface units may become hot enough to cause burns. During and after use, do not touch, or let clothing touch or other flammable materials contact surface units or areas near surface units until they have had enough time to cool. These areas include the rangetop and backguard.

CAUTION

DO NOT TOUCH HEATING ELEMENTS OR INTERIOR SURFACES OF OVEN—Oven heating elements may be hot though they are dark in color. Interior surfaces of an oven may become hot enough to cause burns. During and after use, do not touch, or let clothing or other flammable materials touch, heating elements or interior surfaces of oven until they have had enough time to cool. Other range surfaces that may become hot enough to cause burns are the oven door and oven

WARNING

To avoid personal injury, do not sit, stand or lean on oven door or oven drawer.

WARNING

To avoid risk of electrical shock, personal injury, or death, make sure your range has been properly grounded and always disconnect it from main power supply before servicing.

California Safe Drinking Water and Toxic Enforcement Act (Proposition 65)

The Governor of California is required to publish a list of substances known to the state of California to cause cancer or reproductive harm and requires businesses to warn customers of potential exposures to such substances.

Some appliances contain or produce a chemical or chemicals which can cause death or serious illness and which are known to the State of California to cause cancer, birth defects, or other reproductive harm. To reduce the risk from substances that may be released during the self-cleaning cycle, make sure this appliance is installed, operated, and maintained according to the manufacturer's instructions.

SAVE THESE INSTRUCTIONS

IMPORTANT SAFETY INFORMATION

ALL APPLIANCES

1. Proper Installation—Be sure your appliance is properly installed and grounded by a qualified technician.
2. Never Use Your Appliance for Warming or Heating the Room.
3. Do Not Leave Children Alone—Children should not be alone or unattended in the area where the appliance is in use. They should never be allowed to sit or stand on any part of the appliance.
4. Wear Proper Apparel—Loose-fitting or hanging garments should never be worn while using the appliance.
5. User Servicing—Do not repair or replace any part of the appliance unless specifically recommended in the manual. All other servicing should be referred to a qualified technician.
6. Storage In or On Appliance—Flammable materials should not be stored in an oven or near surface units.
7. Do Not Use Water on Grease Fires—Smother fire or flame, or use dry chemical or foam-type extinguisher.
8. Use Only Dry Potholders—Moist or damp potholders on hot surfaces may result in burns from steam. Do not let potholder touch elements. Do not use a towel or other bulky cloth.

SURFACE COOKING UNITS

1. Use Proper Pan Size—This appliance is equipped with one or more surface units of different size. Select utensils having flat bottoms large enough to cover the surface unit heating element. The use of undersized utensils will expose a portion of the heating element to direct contact and may result in ignition of clothing. Use of oversized utensils concentrates heat on cooking surface and can cause damage to range. Proper relationship of utensil to surface element improves efficiency.
2. Never Leave Surface Units Unattended—Boilover causes smoking and greasy spillovers that may ignite.
3. Protective Liners—Do not use aluminum foil to line oven bottom. Improper installation of these liners may result in a risk of electrical shock, or fire.
4. Glazed Cooking Utensils—Only certain types of glass, ceramic, earthenware, or other glazed utensils are suitable for rangetop service without breaking due to sudden change in temperature.
5. Utensil Handles Should Be Turned Inward and Not Extend Over Adjacent Surface Units—To reduce the risk of burns, ignition of flammable materials, and spillage due to unintentional contact with the utensil, the handle of a utensil should be positioned so that it is turned inward, and does not extend over adjacent surface units.

GLASS/CERAMIC COOKING SURFACES

1. Do Not Cook on Broken Cooktop—If cooktop should break, cleaning solutions and spillovers may penetrate the broken cooktop and create a risk of electrical shock. Contact a qualified technician immediately.
2. Clean Cooktop With Caution—If a wet sponge or cloth is used to wipe spills on a hot cooking area, be careful to avoid to avoid steam burn. Some cleaners can produce noxious fumes if applied to a hot surface.

SAVE THESE INSTRUCTIONS

IMPORTANT SAFETY INFORMATION

OVENS

1. Use Care When Opening Door—Let hot air or steam escape before removing or replacing food.
2. Do Not Heat Unopened Food Containers—Build-up of pressure may cause container to burst and result in injury.
3. Keep Oven Vent Ducts Unobstructed.
4. Placement of Oven Racks—Always place oven racks in desired location while oven is cool. If rack is removed while oven is hot, do not let potholder contact hot heating element in oven.

SELF-CLEANING OVENS

1. Do Not Clean Door Gasket—The door gasket is essential for a good seal. Care should be taken not to rub, damage, or move the gasket.
2. Do Not Use Oven Cleaners—No commercial oven cleaner or oven liner protective coating of any kind should be used in or around any part of the liner.
3. Clean Only Parts Listed in Manual.
4. Before Self-Cleaning the Oven—Remove broiler pan, oven racks, and other utensils.
5. Remove All Items from Rangetop and Backguard.

VENTILATION HOODS

1. Clean Ventilating Hoods Frequently—Grease should not be allowed to accumulate on hood or filter.
2. When flaming foods under the hood, turn the fan on.



CAUTION

Do not store items of interest to children in cabinets above a range or on the backguard of a range—children climbing on the range to reach items could be seriously injured.

In Case of Fire

Fires can occur as a result of over cooking or excessive grease. Though a fire is unlikely, if one occurs, proceed as follows:

Surface Element Fire

1. Smother the fire with a nonflammable lid or baking soda, or use a Class ABC or BC extinguisher. Not water. Not salt. Not flour.
2. As soon as it is safe to do so, turn the surface controls to *OFF*. Turn off power at main circuit breaker or fuse box.

Oven Fires

1. If you see smoke from your oven, **do not** open oven.
2. Turn oven control to *OFF*.
3. As an added precaution, turn off power at main circuit breaker or fuse box.
4. Turn on vent to remove smoke.
5. Allow food or grease to burn itself out in oven.
6. If smoke and fire persist, call fire department.
7. If there is any damage to components, call an authorized servicer before using range.

Precautions

- Do not cook food directly on rangetop surface, always use cookware.
- Do not lift or move range by grasping oven door. This can result in window glass breaking or shattering.
- Do not mix household cleaning products. Chemical mixtures may interact with objectionable or even hazardous results.
- Do not put plastic items on warm cooking areas. They may melt and stick.
- Do not slide rough metal objects across rangetop surface. Scratching or metal marking can result.
- Do not leave fat heating unless you remain nearby. Fat can ignite if overheated by spilling onto hot surfaces.
- Do not allow pots to boil dry as this can cause damage to cooking surface and pan.
- Do not use rangetop surface as a cutting board.
- Do not use range for storage or as a display counter.

SAVE THESE INSTRUCTIONS

Installation

Packing Material

Remove protective packing materials from range. Tape residue can be cleaned with a soft cloth and alcohol.

Range Location

Underwriter's Laboratories, Inc. specifies range can be installed flush against right and left base cabinets, and rear vertical wall. Range can also be installed flush against left or right vertical wall extending above 36 inch standard countertop height.

Cabinet Opening



WARNING

To avoid risk of burns or fire by reaching over elements, cabinet storage space located above range should be avoided. If cabinet storage is provided, install a range hood that projects horizontally a minimum of 5 inches beyond the cabinet bottom to reduce the risk.



CAUTION

Do not store items of interest to children in cabinets above a range or behind the backguard of a range. Children climbing on the range to reach items could be seriously injured.

Range should extend approximately 2 inches from cabinet front to oven door handle. Using dimensions, prepare cabinet opening.

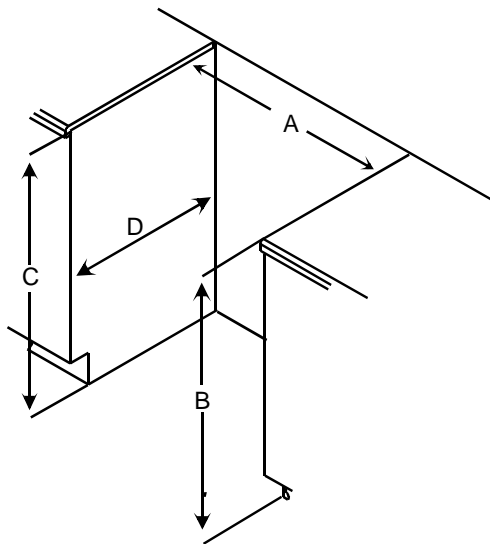

- A—30¹/₈ to 30¹/₄ inches
- B—36 inches standard
- C—35 inches standard
- D—24 inches standard

Minimum Clearances to Combustible Surfaces

Using dimensions, prepare cabinet opening.

- Minimum clearance to rear wall is 0 inches.
- Minimum clearance to a vertical right or left side wall is 0 inches.
- Minimum clearance to countertop/cabinet on each side is 0 inches.
- Minimum of 30 inches between top of cooking surface and bottom of an unprotected wood or metal cabinet.
- Minimum of 24 inches between cooking surface and protected wood or metal cabinet above range. Cabinet bottom must be protected by at least 1/4 inch thick millboard with not less than No. 28 MSG sheet steel, .015 inch thick stainless steel, .024 inch thick aluminum, or .020 inch thick copper.

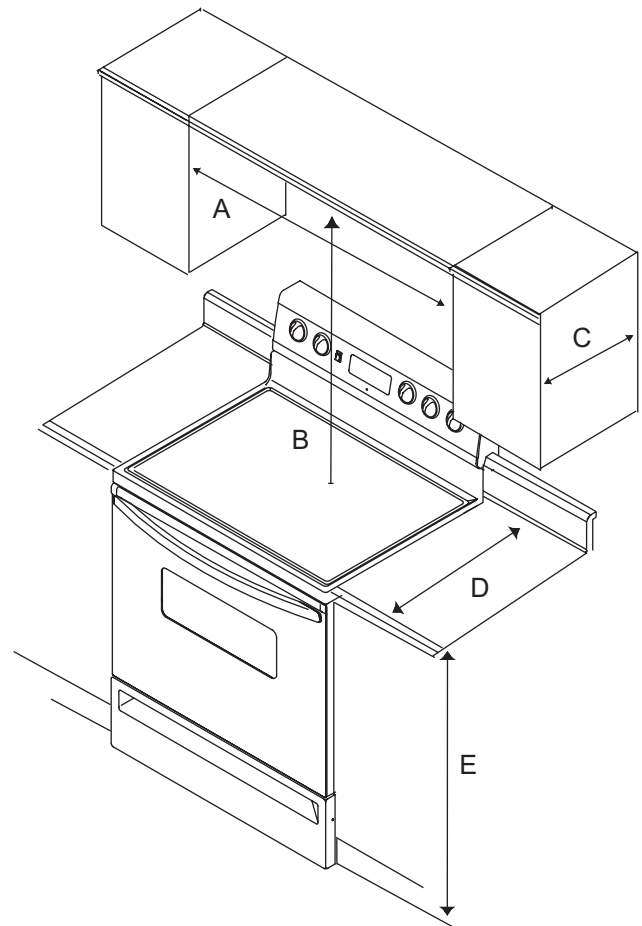

- A—30 inches minimum
- B—30 inches unprotected / 24 inches protected minimum
- C—13 inches maximum
- D—25 inches maximum
- E—36 inches maximum

Minimum Clearances to Combustible Surfaces

Irregular Cabinet and Countertop Heights

Countertops such as ceramic tile tops cause cabinet and countertop to be higher than 36 inches. Follow instructions below when countertop is higher than 36 inches.

1. Raise leveling legs to maximum height.
2. Measure from floor to rangetop. If measurement is less than height of countertop, floor must be shimmed.
3. Shim floor using a piece of plywood same size as range opening. Secure plywood to floor. Plywood must be as secure as original flooring.
4. Install anti-tip bracket and slide range into place.

Line Voltage Requirements

Range needs a 3 or 4 wire 120/240 VAC, 40 amp minimum, 60 Hertz, single phase electrical supply. Wiring system and grounding must conform with the latest edition of Underwriters Laboratories, Inc. Standards, the National Electric Code, ANSI/NFPA 70, or the Canadian Electrical Code, CAS C22.1. Installation must conform to all local, municipal and state building codes, and local utility regulations. Connect range to power supply with MAXIMUM RATED VOLTAGE listed on the rating plate. Line voltage must not exceed rated voltage.

Power Supply Location

Shaded area shows range clearance for electrical connection.

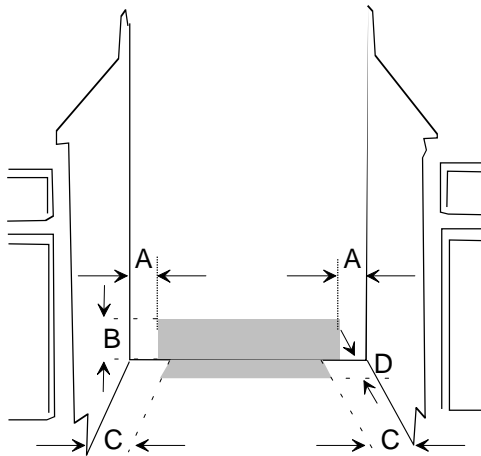

- A—3 inches
- B—6 inches
- C—6 inches
- D—3 inches

Power Supply Location

Power Cord Requirements

Power cord is not supplied with range. Power cord must be U.L. or C.S.A. listed and meet NEC and Mobile Home Manufacturers Association Standards. Cord must be rated at a minimum 250V 40 AMP, equipped with a plug configuration in accordance with NEMA. Conductors must end with closed loop (ring) terminals at the range.

- Three-conductor cord plug NEMA 10-50P allowed for residential.
- Four-conductor cord plug NEMA 14-50P required for most mobile home installations but can be used for residential.

NOTE: Only a power cord suitable for use with ranges may be used. For installation in a mobile home, or area where local codes (Canada) do not permit grounding through the neutral terminal, a 4-wire cord must be used.

Range Terminal Block

Connection block is located at bottom rear of range behind rear cover panel. Remove rear cover screw. Directly below terminal block is a hole for a power supply cord. Power cord is not supplied with range.

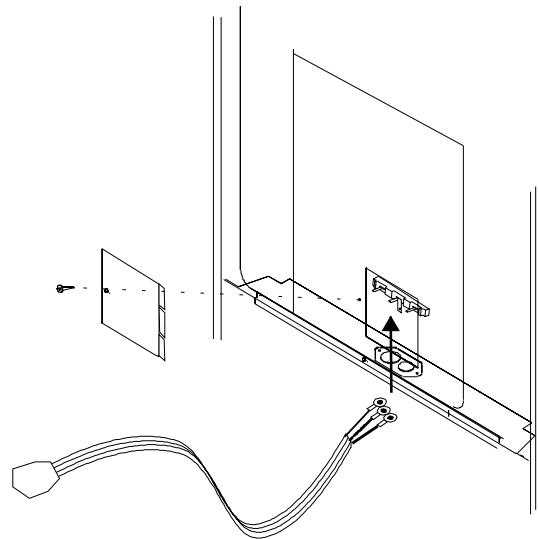

Installing Power Cord

Installation (cont.)

Range has been grounded at the factory to the center (nickel plated) terminal of the terminal block in accordance with the National Electrical Code (section 2560). When a separate ground is required by local code, disconnect the grounding strap from the terminal block. Ground frame by connecting a grounding wire to range frame using **only** the grounding screw removed from the grounding strap.

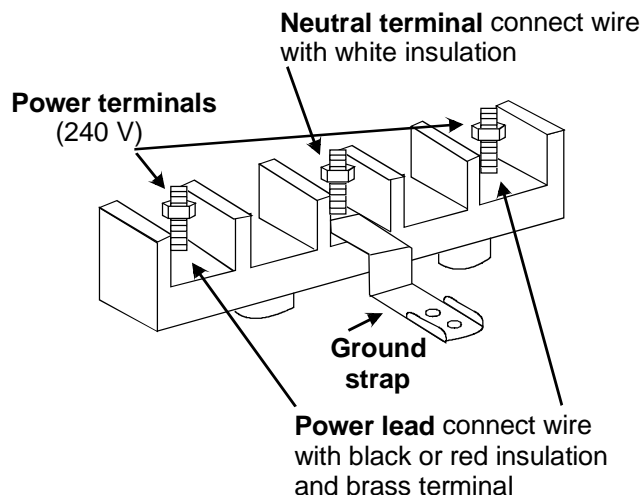

Range Terminal Block

Terminal block is approved for copper wire connection only, NOT aluminum wiring. If aluminum house wiring is to be connected, the following procedure is suggested.

1. Connect length of copper building wire to range terminal block with ring terminals.
2. Splice copper wires to aluminum wiring using connectors which are design certified by Underwriter's Laboratories and recognized for joining copper to aluminum. Follow the connector manufacturer's recommended procedure.
3. Wire used, location and enclosure of splices must conform to local codes.

Installing 3-Wire Power Cord

Refer to power cord instructions if available for additional information.

1. Remove wire cover on rear of range.
2. Place strain relief (winged clamp) in cord access hole below terminal block.
 - Strain relief is supplied with cord, not range. Place wings through hole, entering from bottom. Screw holes in clamp should be below mounting panel. Place cord through strain relief.
3. Attach neutral (center) or white wire to center terminal on terminal block.
4. Attach power lead, red wire or black wire, to left side power terminal.
5. Attach power lead, red wire or black wire, to the right side power terminal.
6. After wires have been placed on terminals, attach with hex nuts provided.
 - Firmly tighten to ensure proper electrical connection.
7. Place screw through strain relief and tighten.
8. Replace rear wire cover.

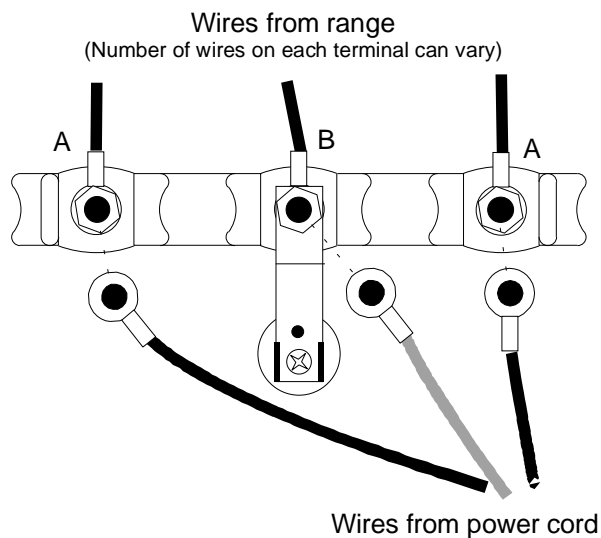

- A—Power lead terminal (Connect black or red insulated wire and secure with brass nut.)
B—Neutral terminal (Connect insulated white insulated wire and secure with brass nut.)

3-Wire Power Cord

Installing 4-Wire Power Cord



WARNING

To avoid risk of severe electrical shock or death, ground wire must be attached to frame of range, using ground screw provided. Ground wire must not contact any other terminal.

1. Remove rear wire cover on back of range.
2. Place strain relief (winged clamp) in cord access hole below terminal block.
 - Strain relief is supplied with cord. Place wings through hole entering from bottom.
 - Screw holes in clamp should be below mounting panel.
3. Remove green ground screw (retain for use in step 8) and unscrew brass nut on center terminal. Remove grounding strap.

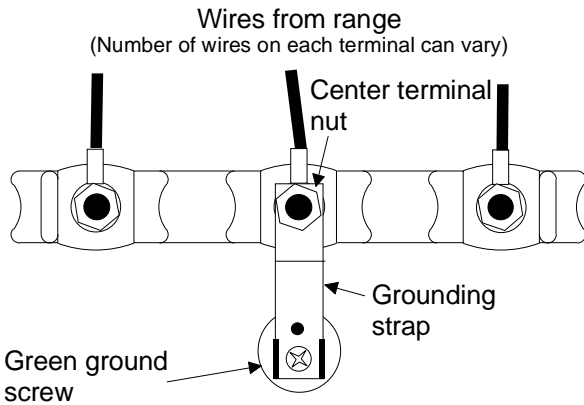

Terminal Block Grounding Strap, Screw and Center Nut

4. Place cord through strain relief.
5. Attach cord neutral (center) or white wire to center terminal on terminal block. Secure with hex nuts provided.
6. Attach power lead, red wire or black wire to left terminal. Secure with hex nuts provided.
7. Attach power lead, red wire or black wire to right terminal. Secure with hex nuts provided.

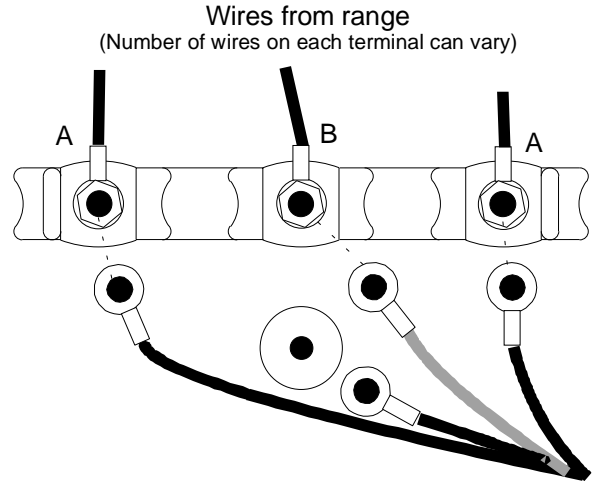

Wires from power cord

A—Power lead terminal (Connect black or red insulated wire and secure with brass nut.)

B—Neutral terminal (Connect insulated white insulated wire and secure with brass nut.)

Installing 4-Wire Power Cord

8. Position grounding strap down and away from terminal block. Attach green or bare wire and grounding strap to back of range using green ground screw previously removed in step 3.

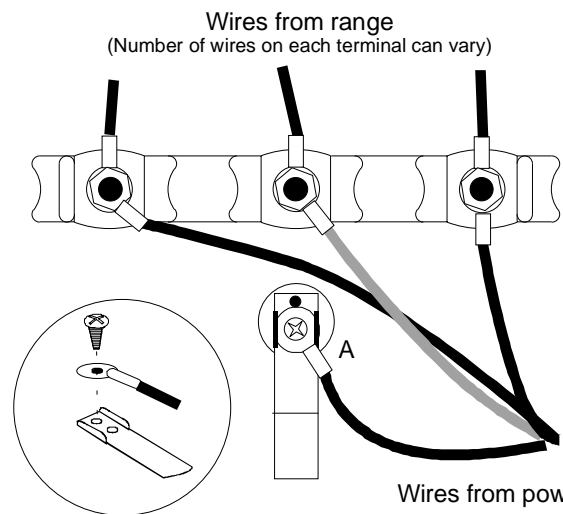

A—Ground screw (Connect green insulated wire and secure with screw.)

Position Grounding Strap

9. Firmly tighten all connections to ensure proper electrical connection.
10. Place screw through strain relief, tighten, and replace rear wire cover.

Installation (cont.)

Converting 3-Wire to 4-Wire Power Cord

1. Remove rear wire cover.
2. Remove bottom strain relief screw and retain for further use.
3. Remove screw/hex nuts from terminal block and retain for further use.
4. Remove all 3-wire or cable leads from the terminal block and proceed to remove the power cord from the range by pulling in a downward motion so the cord is removed from strain relief.
5. To install the 4-wire cord, please follow step 3 through step 9 of *Installing 4-Wire Power Cord* section.

Anti-tip Bracket Installation

To reduce risk of range tipping, secure range with a properly installed anti-tip bracket.

1. Measure 3½ inches from back wall on right and left side of cabinet cutout. Mark measurements on floor and draw a straight line connecting marks.
2. Position anti-tip bracket.
 - If range is installed beside cabinet(s), place anti-tip bracket with back edge on line drawn on floor and side of bracket against cabinet.
 - If range is not installed beside cabinet(s), position range where it will be installed. Draw a line along side of range on floor from front to back. Remove range. Place anti-tip bracket with back edge over line drawn 3½ inches from back wall and side of bracket over line drawn along side of range on floor.
 - Anti-tip bracket can be installed on either right or left side.

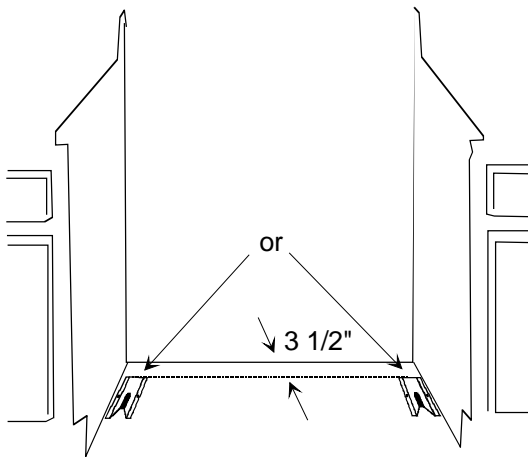

Anti-tip Bracket Installation

3. Mark 2 hole locations in anti-tip bracket.
4. Drill 2 holes.
 - If drilling into wood, use a 3/32-inch drill bit.
 - If drilling into concrete, use a 3/16-inch masonry drill bit and insert plastic anchors.

5. Secure bracket to floor using screws supplied. Slide range into position.
6. Remove range storage drawer or lower panel and confirm anti-tip bracket is engaged with range leveling leg after sliding range into position.

Place and Level Range



To avoid damaging oven door, do not lift or move range by oven door handle. Glass can break.

1. Carefully level range using legs provided. Range must be level to cook and bake uniformly.
 - Place a level on top oven rack or on range top when leveling.
 - Leveling legs must extended at least ¼ inch to engage anti-tip bracket.
2. Plug in range cord.
3. Slide range into position
4. Remove range storage drawer or lower panel and confirm anti-tip bracket is engaged with range leveling leg after sliding range into position.

Removal and Reinstallation of Range

1. Disconnect power to range.
2. Slide range forward.
3. Unplug range cord and place range aside.
4. Remove anti-tip bracket.
5. Install anti-tip bracket into new location using instructions provided with bracket or see *Anti-tip Bracket Installation* section in this manual.
6. To reinstall range, follow instructions in *Installation* section of this manual.

Hot Zones

Shaded areas can become hot while cooking, baking, broiling, or self-cleaning.

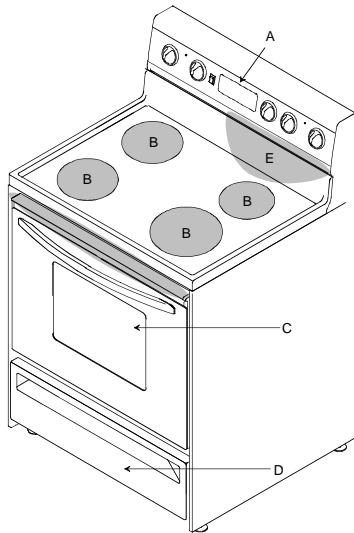

Range Areas

- A—Range Control Panel
- B—Surface Elements (Coil or Smoothtop)
- C—Oven Window
- D—Storage Drawer or Panel
- E—Oven Vent Area (Smoothtop)

Before Cooking with Smoothtop Elements



WARNING

To avoid risk of serious personal injury never cook on a broken smoothtop cooking surface. Spillovers or cleaners can penetrate surface and create a risk of electrical shock. If smoothtop cooking surface breaks, discontinue use and notify an authorized servicer immediately.

- Before cooking on smoothtop, wipe top with cleaner conditioner. Conditioning smoothtop before use makes marks and stains easier to remove.
- Use heavy-gauge metal cookware not including cast iron.
- Bottom of cookware must be flat. Cookware that is warped or slightly curved on the bottom heats slowly and may not boil water. Cookware with an aluminum disk bottom makes excellent contact with cooking surface. See *Utensil Recommendations* section for more information.
- Do not use glass, glass-ceramic, or enamel-porcelain cookware. Small imperfections on bottom of such cookware can scratch smoothtop surface.
- Smoothtop cooking surface is not “scratch proof”. Surface is highly scratch and impact resistant. With recommended cooking utensils and proper care, it will continue looking good through years of use.

Using the Surface Elements

Operating Surface Elements



WARNING

To avoid risk of serious personal injury, property damage, or fire, do not leave surface elements unattended while in operation. Grease and spillovers can ignite causing a fire.

1. Push in and turn surface element control to desired setting.
 - Some ranges have two indicator lights, one for elements on right side and one for elements on left side of range. When either front or rear element is on, corresponding indicator light glows.
 - Some ranges have one indicator under clock. When any element is on, indicator light glows.
 - Smoothtop ranges can have one or two hot indicator lights. After the surface controls are turned off, the appropriate surface indicator light will continue to glow until the surface elements have cooled.
The length of time each light remains on will vary. Do not expect the lights for two different heating areas to go off at the same time even if the elements were turned off simultaneously.
2. When finished cooking, turn control to *OFF* position.

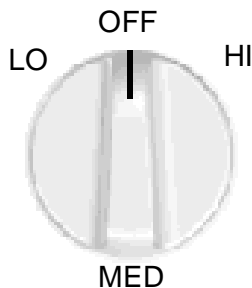

Surface Element Control Knob

Surface Element Settings

LO—Use to prepare food at less than boiling temperatures or to simmer.

MED—Use to maintain boiling of larger amounts of food, low temperature frying and to maintain correct pressure in a pressure cooker.

HI—Use to bring food to boiling temperatures. When food is boiling temperature setting should be reduced to LO through MED.

Cooking with Dual Radiant Element

Dual Element can be operated using inner element only or both elements.

To use inner element

1. Depress *Element Size* switch downward. Dual Element switch is located on right side of control panel next to surface element control knob.

LARGE

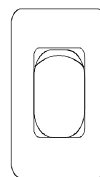

SMALL

Element Size Switch

2. Push in and turn surface element control to desired setting.
 - Element will cycle on and off to maintain desired heat setting.

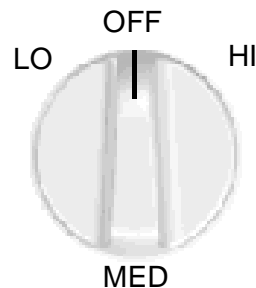

Surface Element Control Knobs

3. When finished cooking turn control to *OFF* position.

To use both inner and outer element

1. Depress *Element Size* switch upward.
2. Follow steps 2-3 above.

LARGE

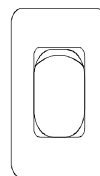

SMALL

Element Size Switch

Utensil Recommendations

Cooking Utensils

- Use proper pan size. Do not use a pan that has a bottom smaller than element. Do not use utensils that overhang element by more than 1 inch.

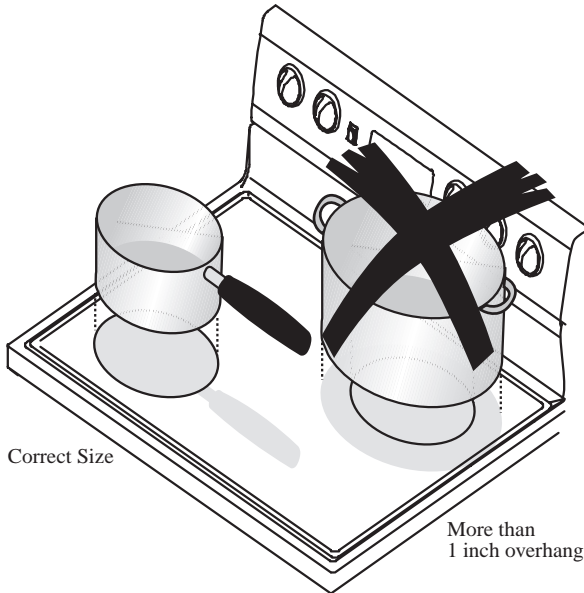

Use Proper Pan Size

- Select utensils without broken or loose handles. Handles should not be heavy enough to tilt pan.
- Do not use a wok with a ring stand. Use flat bottom wok.

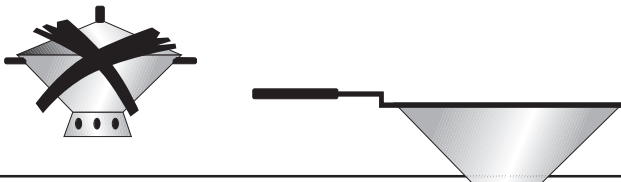

Use Flat Wok

Utensil Material Characteristic		
Type	Temperature Response	Uses
Aluminum	Heats quickly	Frying, braising, roasting
Copper Clad / Tin Lined	Heats and cools quickly	Gourmet cooking, wine sauces, egg dishes
Stainless Steel	Heats and cools at moderate rate	Soups, sauces, vegetables, general

For best cooking results, use a pan with a flat bottom. Determine if pan has a flat bottom.

1. Rotate a ruler along bottom of pan. If pan is not flat, gaps between bottom of pan and edge of ruler occur.
2. A small groove or mark on a pan does not affect cooking times. However, if a pan has a gap, formed rings, or an uneven bottom, it does not cook efficiently and in some cases may not boil liquid.

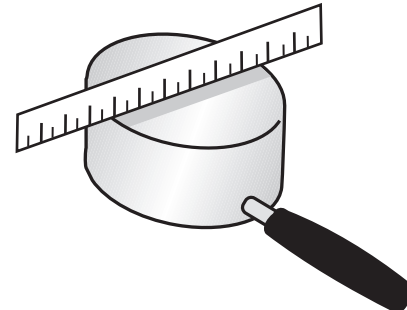

Use Flat Bottom Pans

Canning

Canning is not recommended with Caloric's smoothtop ranges due to the intense heat and large cookware required to can.

The heat generated by the canning cookware overheats both the elements and the smoothtop of the range. This can cause the smoothtop to crack, cause failure of the heating elements, and can cause damage to the backguard.

Damage incurred by canning, or attempting to can, using the smoothtop cooktop is not covered under warranty.

Electronic Oven Control and Oven Switches

CONVECTION

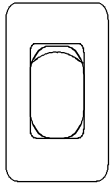

STANDARD

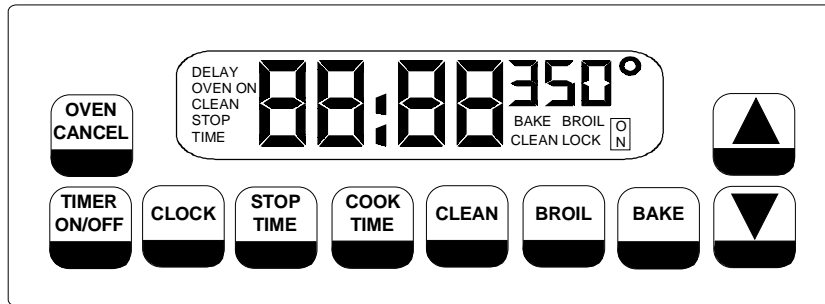

OVEN LIGHT

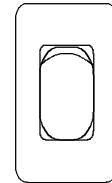

Electronic Oven Control

Pad	Description
OVEN CANCEL	Cancels any cooking or cleaning function except timer.
TIMER ON/OFF	Use to time any kitchen function or cancel timer. Does not control bake, broil, or clean function.
CLOCK	Use to set time of day. 12-hour clock does not display AM, PM or military time.
STOP TIME	Use to set delayed bake and self-clean.
COOK TIME	Use to set timed baking.
CLEAN	Use to select self-clean cycle.
BROIL	Use to select broil.
BAKE	Use to select bake.
▼ or ▲	Use to set temperature or time.

Oven Signals

Timer signal	When time elapses, timer beeps 3 times then approximately once every 6–8 seconds until TIMER ON/OFF pad is pressed.
Preheat signal	After setting oven to bake and selecting a temperature, oven preheats. When oven reaches set temperature, 1-second signal sounds.
End-of-Cycle signal	When a timed cooking cycle is complete, three long signals sound. End of cycle signal continues to sound until OVEN CANCEL pad is pushed. If minute timer end of cycle signal is sounding, push TIMER ON/OFF pad.

Oven Switches

Oven Light Switch	Oven light turns on when oven door is opened or when switch on control panel is turned on.
Convection / Standard Switch (Convection models)	When pushed up towards “CONVECTION”, convection oven fan turns on and switch glows. When cooking is complete, press switch towards “STANDARD” to turn fan off. Do not use convection for Self-cleaning or normal baking; push down towards “STANDARD”.

Display and Features



Displays time-of-day, timer and timed or delayed bake settings.



Displays temperature and cooking method for oven.

Display Glossary

TIME	TIME displays while time-of-day, timed or delayed baking, or delayed self-cleaning is set.
BAKE	BAKE displays while bake is set and used.
ON	Displays when oven is in use.
DELAY	Displays when delayed bake or clean self-cycle is set. Oven is not heating.
STOP	Displays when setting the stop time for a delayed baking or self-clean cycle.
BROIL	Displays when a broil is set and used.
CLEAN	Displays when self-clean cycle is set and used.
LOCK	LOCK flashes while oven door is locking and remains in display while door is locked. After cycle is complete and oven has cooled to a safe temperature, LOCK no longer displays and door can be opened.

Other Features

12-hour automatic cancel	This safety feature prevents oven from continuing to operate if it has been left on for over 12 hours. If a cooking function continues longer than 12 hours without any options on oven control being touched, this feature turns oven off. Any time an option is touched, 12-hour automatic cancel is reset.
Child lockout	This safety feature is used to prevent children from accidentally programming oven by disabling electronic oven control. Press and hold BAKE and COOK TIME for 5 seconds. "OFF" displays where the temperature normally appears. To reactivate control, press and hold BAKE and COOK TIME pads for 5 seconds on the upper oven control. Child lockout must be reset after a power failure.
Service codes and tones	Electronic oven control is equipped with a self diagnostic system. Self diagnostic system alerts you if there is a error or problem in the control. If electronic range control sounds a series of short, rapid beeps for over 16 seconds and display shows a F-code, record the F-code shown. Some F-codes can be cleared by touching OVEN CANCEL or disconnecting power to the range. If the code continues to reoccur call an authorized servicer. Disconnect electrical supply to range and contact an authorized servicer. F1—Shorted pad button F2—High oven temperature F3—Temperature sensor malfunction F4—Temperature sensor malfunction F5—Control malfunction F7—Door lock malfunction (Door locked) F9—Door lock malfunction (Door unlocked) DOOR—Door lock malfunction

Setting the Clock and Timer

CONVECTION

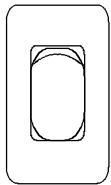

STANDARD

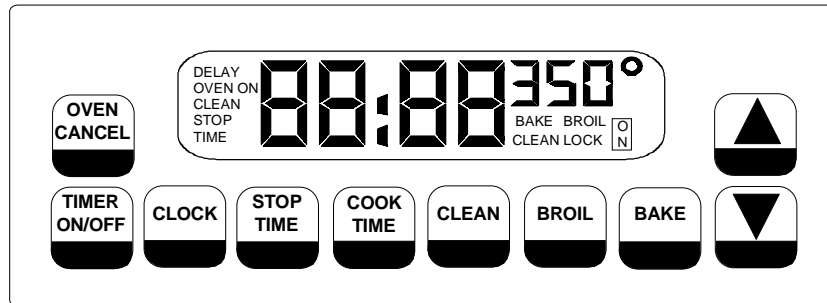

OVEN LIGHT

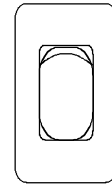

Setting Clock

1. Press CLOCK pad.
 - "TIME" displays.
2. Press ▲ or ▼ pad until correct time of day is displayed.
3. Press OVEN CANCEL pad to set time.
 - If OVEN CANCEL pad is not pressed, approximately 30 seconds after last entry, "TIME" disappears and time is set.

Setting Minute Timer

1. Press TIMER ON/OFF pad.
 - "TIMER" displays.
2. Press ▲ or ▼ pad until desired amount of time is displayed.
 - Timer can be set from 5 seconds to 9 hours and 50 minutes.
 - Timer begins counting down automatically.
3. When time elapses timer beeps 3 times then approximately once every 6-8 seconds.
 - Press TIMER ON/OFF to cancel beep but remain in timer mode.

Canceling Minute Timer

Press and hold the TIMER ON/OFF pad for approximately 3 seconds.

- When canceling minute timer do not press OVEN CANCEL pad. Pressing OVEN CANCEL pad cancels cooking function.

Adjusting Factory Set Baking Temperature

Your new range oven is calibrated at the factory for temperature. However, due to individual variances and preferences, it may be necessary to adjust individual ovens once they have been installed.

When first using the oven, follow recipe times and temperatures. Before adjusting oven baking temperature, test a recipe by using a temperature set higher or lower than the recommended temperature. The baking results should help you decide how much adjustment is needed.

Prior to adjusting the baking temperature, check for blocked heat vents. Remove aluminum foil from oven—it will alter oven temperature. If it still appears the oven is not performing as expected, a calibration may be done. An accurate digital thermometer is necessary to calibrate oven. Store purchased oven thermometers do not measure oven temperature accurately.

To change oven temperature through oven control:

1. Push BAKE pad.
2. Push up or down arrow pad until an oven temperature more than 500°F shows.
3. Immediately push and hold BAKE pad until "00" shows (approximately 5 seconds).
4. To decrease oven temperature (for a cooler oven), Push down arrow pad until negative numbers appear. Oven can be adjusted from -05° to -35° lower. To avoid over adjusting oven move temperature -5° each time.
5. To increase oven temperature (for a warmer oven), Push up arrow pad until positive numbers appear. Oven can be adjusted from 5° to 35° higher. To avoid over adjusting oven move temperature 5° each time.
6. Push OVEN CANCEL button. Temperature adjustment will be retained even through a power failure.

Oven Cooking Methods

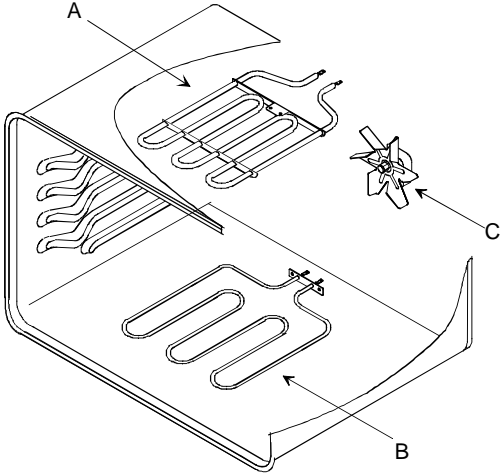
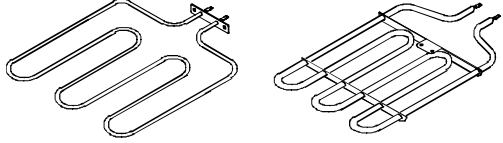
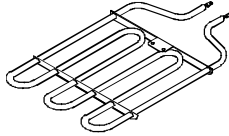
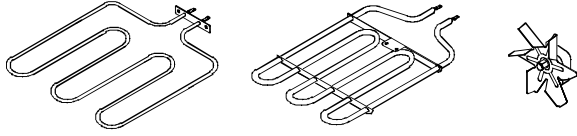
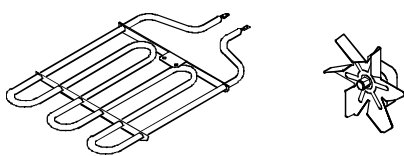
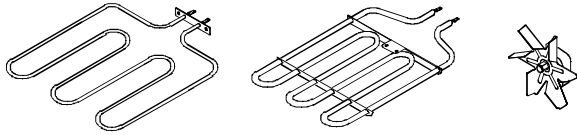
<p>Introduction These ranges provide standard Baking and Broiling, and in some models Convection Baking and Broiling. During Convection Baking and Broiling, the oven fan in the rear of the oven cavity circulates air while the oven cooks. The circulating air provides even browning and faster baking and broiling times.</p> <p>When a convection oven is set to standard mode, the CONVECTION/STANDARD switch next to electronic range control is pressed towards "STANDARD" and does not glow. To set oven to Convection Cooking, press switch towards "CONVECTION". The switch glows and the oven fan operates. When cooking is complete, press switch towards "STANDARD" to turn fan off.</p>	<p>Element and Fan Location</p>  <p>A—Upper Element (Broil) B—Lower Element (Bake) C—Convection Fan (Some models)</p>
<p>Bake Upper and lower elements operate during bake. Upper element is only used to heat oven quickly and brown top of food. Bake can be used to cook foods that are normally baked. Oven must be preheated.</p>	
<p>Broil Upper element operates during broil. Broil can be used to cook foods which are normally broiled. Preheating is not required when using broil. All foods should be turned at least once except fish, which does not need to be turned.</p>	
<p>Convection Bake (some models) Upper element, lower element, and fan operate during convection bake. Upper element is only used to heat oven quickly and brown top of food. Convection bake should be used for cooking casseroles and roasting meats. Oven should be preheated for best results when using convection bake. Pans do not need to be staggered. Cooks approximately 25% quicker than standard bake.</p>	
<p>Convection Broil (some models) Upper element and fan operate when using convection broil. Convection broil can be used to cook foods that are normally broiled. Oven does not require preheating when using convection broil. Cooks approximately 25% quicker than standard broil.</p>	
<p>Dehydrate (some models) Uses convection fan with oven at low temperature (approx. 170°F). Dehydration is an excellent way to preserve fresh foods.</p>	

Baking and Broiling



CAUTION

To reduce risk of food poisoning due to bacterial growth and production of toxins, never hold meat, milk, fish or eggs for more than 2 hours before cooking.

Remove Items Stored in Oven

Remove any pans and other cooking utensils stored in oven.

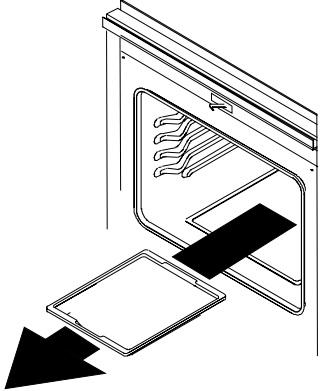

Remove Items Stored in Oven



WARNING

To avoid damaging oven liner or creating fire, do not line oven bottom or oven racks with foil or aluminum liners.

Oven Rack Placement

Position oven rack before turning oven on.

1. Pull rack forward to stop position.
2. Raise front edge of rack and pull until rack is out of oven.
3. Place rack in new rack position.
 - Curved edge of rack must be toward rear of oven.

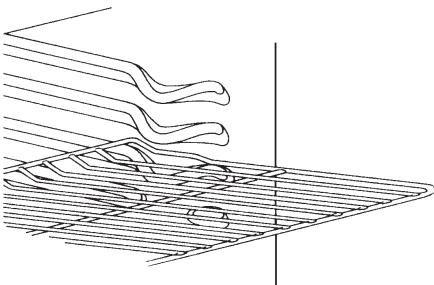

Bake Pan Placement

- Keep pans and baking sheets 2 inches from oven walls.
- Stagger pans placed on different racks so one is not directly over the other.

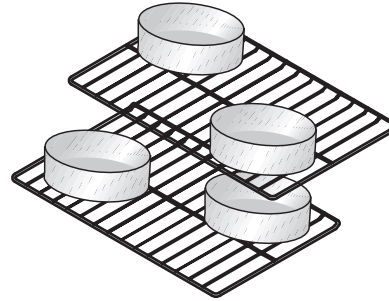

Pan Placement

Convection Pan Placement

Baking pans and cookie sheets should not touch side or rear walls of oven. If pans are placed on different racks, they can be placed directly over each other. Convection cooking circulates air around oven providing even browning on all rack positions. When using convection, oven can be loaded on all racks with excellent cooking results.

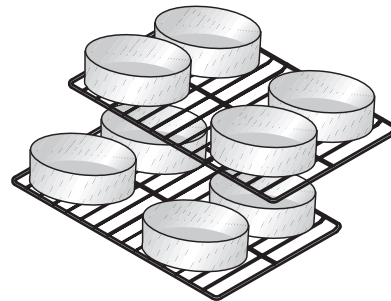

Convection Pan Placement

Aluminum Foil

When placed on the oven bottom or racks, aluminum foil not only creates a hazard, but also affects cooking performance. To minimize spills in the oven, place a shallow pan or cookie sheet underneath food items that may drip or spill.

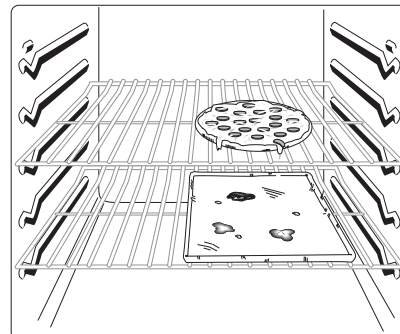

Baking or Convection Baking

Open oven door to confirm nothing is stored in oven cavity and set racks to proper height before baking. For delicate baking, preheat approximately 15–20 minutes before placing food inside oven.

1. Press **BAKE** pad.
 - “BAKE” and “---°” display.
2. Press **▲** or **▼** pad until desired temperature is displayed.
 - Temperature begins at 350°F and can be set from 170°F to 550°F in 5 degree increments.
 - Temperature starts at 100°F and increases in 5° increments until reaching set temperature. Some minor smoking is normal when using oven for first time. When cook temperature is reached oven signal sounds for approximately 1 second.
3. Press **CONVECTION/STANDARD** switch towards **CONVECTION** for convection cooking. Switch glows in convection mode and fan runs..
4. Press **OVEN CANCEL** pad when finished.
 - Remove food from oven when cooking time has elapsed. Food left in oven can overcook.
 - Press **CONVECTION/STANDARD** switch towards **STANDARD** when baking is finished. Switch stops glowing and fan stops running.

Timed Baking or Timed Convection Baking

Set oven to cook for desired amount of time. Oven starts immediately and automatically stops heating after time elapses.

1. Place food in oven.
2. Press **COOK TIME** pad.
3. Press **▲** or **▼** pad until cooking time is displayed.
 - Cook time can be set up to 11 hours and 55 minutes.
 - 10 minutes minimum cooking time.
 - If cook time is entered and temperature not entered “BAKE” and ---° flashes and signals.
4. Press **BAKE** pad.
5. Press **▲** or **▼** pad until desired temperature is displayed.
 - Temperature begins at 350°F and can be set from 170°F to 550°F in 5° increments.
 - Temperature display increases in 5°F increments starting at 100°F until reaching set temperature. Some minor smoking is normal when using oven for first time. When cook temperature is reached oven signals.
 - To view cook time, press **COOK TIME** pad.
 - When cooking time has elapsed, an end of cycle signal sounds, oven automatically turns off and display returns to time of day. Oven signal sounds 3 times, then once every 3 seconds for 5 minutes or until **OVEN CANCEL** pad is pressed.
6. Press **CONVECTION/STANDARD** switch towards **CONVECTION** for convection cooking. Switch glows in convection mode.
7. Press **OVEN CANCEL** pad when finished.
 - Remove food from oven when cooking time has elapsed. Food left in oven can overcook.
 - Press **CONVECTION/STANDARD** switch towards **STANDARD** when baking is finished. Switch stops glowing.
 - To cancel remaining cooking time press **OVEN CANCEL** pad.

Baking and Broiling (cont.)

Delayed Baking or Delayed Convection Baking

Set oven to begin and end baking at later time. Range control automatically calculates starting time.

1. Place food in oven.
2. Press BAKE pad.
3. Press ▲ or ▼ pad until desired temperature is displayed.
 - Temperature begins at 350°F and can be set from 170°F to 550°F in 5° increments.
4. Press STOP TIME pad.
 - Current time of day appears in display.
5. Press ▲ or ▼ pad until desired stop time displays.
 - Stop time can be set 11 hours 55 minutes ahead of current time of day.
6. Press COOK TIME pad.
 - To view cook time later, press COOK TIME pad.
7. Press ▲ or ▼ pad until desired time cooking displays.
 - 10 minutes minimum cooking time.
 - Electronic range control calculates start time. When start time is reached “DELAY” no longer displays and “N” displays.
 - To view cook time, press COOK TIME pad.
 - To view stop time, press STOP TIME pad.
8. Press CONVECTION/STANDARD switch towards CONVECTION for convection cooking. Switch glows in convection mode and fan runs.
9. When cooking time has elapsed, end of cycle signal sounds, oven automatically turns off and display returns to time of day. Oven signal sounds 3 times, then once every 3 seconds for 5 minutes or until OVEN CANCEL pad is pressed.
 - Press CONVECTION/STANDARD switch towards STANDARD when baking is finished. Switch stops glowing.
 - To cancel remaining cooking time press OVEN CANCEL pad.

Broiling or Convection Broiling

Broiling system generates immediate, intense heat using a special reflector. This reflector focuses heat directly on the food; searing in natural juices and providing restaurant quality, charbroiled flavor.



WARNING

To avoid risk of fire, do not line the broiler grid with foil.

- Foil may trap grease on top of grid close to burner causing a fire.
- Never leave oven unattended while broiling. Overcooking may result in a fire.

Broiling Tips

- Remove excess fat from meat before broiling. Cut edges of meat to prevent curling.
- Place food on a cold ungreased broiling pan. If pan is hot, food sticks.
- All food except fish should be turned at least one time. Begin broiling with skin side down.
- Season meat after it has browned.
- Broiling does not require preheating.
- Begin cooking using suggested rack levels in *Broiling Guide* section to test broiler results. If food is not brown enough, cook on a higher rack position. If food is too brown, cook on a lower rack position.

Broiling or Convection Broiling

1. Center food on broiling grid and pan, and place on rack in oven.
 - During broiling, oven door should be closed.

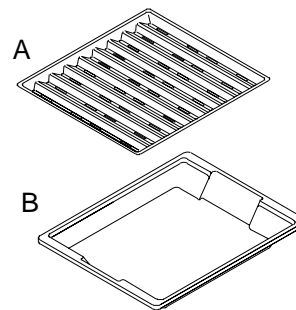

A—Broiler Grid
B—Broiler Pan

Broiler Pan and Grid

2. Press BROIL pad.
 - “BROIL” and “---” displays.
3. Press ▲ or ▼ to set from HI to settings 5 thru 1.
 - Oven begins to broil within 5 seconds. “BROIL”, “” and “HI” or “5 thru 1” setting display.

Broiler Setting	Approximate Temperature	Use
HI	600°F	Cooking red meats
5	550°F	Cooking pork
4	525°F	Cooking poultry
3	475°F	Cooking seafood
2	425°F	Cooking fruits and vegetables
1	400°F	Toasting breads

4. Press CONVECTION/STANDARD switch towards CONVECTION for convection cooking. Switch glows in convection mode.
5. Press OVEN CANCEL pad when finished.
 - Remove food from oven when cooking time has elapsed. Food left in oven can overcook.
 - Press CONVECTION/STANDARD switch towards STANDARD when baking is finished. Switch stops glowing.

Dehydration

Dehydration is an excellent way to preserve fresh foods. The best way to become familiar with dehydration is using fruits, vegetables, herbs and spices.

1. Place food on dehydration rack or cookie sheet in middle of oven.
2. Open door to first stop position.
3. Press BAKE pad.
4. Press ▼ until 170° appears in display.
 - Oven is equipped with a 12 hour automatic cancel feature. If dehydration time is longer than 12 hours, control will need to be reset.
5. Press CONVECTION/STANDARD switch towards CONVECTION for convection cooking. Switch glows in convection mode.
6. When finished press OVEN CANCEL pad.
 - Press CONVECTION/STANDARD switch towards STANDARD when baking is finished. Switch stops glowing.

Dehydration Tips

Fruits

- Always start with fresh fruit.
- Cut fruit in equal pieces approximately 1/8” thick. Thinner pieces will dry quicker.
- Fruits need to be dipped into an antioxidant, a color-keeping preservative, or two parts water and one part lemon juice. Treating fruit with an antioxidant will help it retain vitamins, color and flavor.

Vegetables

Most vegetables require blanching to inactivate enzymes.

Herbs and Spices

- Herbs and spices dry quickly.
- Check every 30 minutes to avoid over drying.
- When drying herbs, leaf clusters should be separated from stems.

Food	Drying Time	Results
Fruits		
Apples	4–6 hours	Leathery, Soft
Bananas	16–20 hours	Leathery
Vegetables		
Mushrooms (No blanching)	3–4 hours	Leathery, Soft
Carrots	3–7 hours	Dry, Brittle
Herbs and Spices		
Parsley	45–90 minutes	Dry, Crumbly
Orange/ Lemon Peel	3–7 hours	Hard, Tough

Self-Clean



WARNING

To avoid risk of personal injury, do not touch oven vents or areas around vents during self-cleaning. These areas can become hot enough to cause burns.

To avoid risk of smoke damage or fire, clean excess spills from oven interior.



CAUTION

To avoid fire or smoke damage, remove any flammable materials from storage drawer. Items like plastic containers and paper manuals can melt or burn. Flammable materials should never be stored in the storage drawer.

- A small amount of smoke is normal when cleaning. Excess smoke may indicate a faulty gasket or too much food residue has been left in oven. **Move birds and small animals susceptible to fumes or smoke to another room.**
- Oven should be cleaned before it gets too dirty. Wipe up large spills before self-cleaning.
- Do not use cleaning cycle if oven light cover is not properly in place.
- Remove oven racks and all cooking utensils from oven.
- Clean excess spills from oven interior.
- Remove items from range top and backguard. These areas can become hot during self-cleaning cycle.
- Area around oven door and cavity will not self-clean since the high heat cannot reach this area.

Self-cleaning

Self-clean feature uses high oven temperature to clean oven interior.

1. Prepare oven for self-cleaning.
 - Verify CONVECTION/STANDARD switch towards STANDARD and switch is not glowing.
2. Press CLEAN pad.
3. Press ▲ or ▼ pad to adjust cleaning time.
 - “3:00” displays when ▲ or ▼ is pressed.
 - Increase or decrease cleaning time by 5 minute increments.
 - Clean can be set from 2 to 4 hours. Minimum recommended cleaning time is 3 hours.
 - Oven begins to clean immediately. “LOCK” flashes in display when automatic door latch is locking.
 - When oven has cooled to a safe temperature, door latch opens and “LOCK” light flashes while opening. When oven has cooled enough to open door “LOCK” light no longer displays and door can be opened.
 - When self-clean is finished, there will not be an end-of-cycle signal.

Interrupt Self-Clean Cycle

1. Press OVEN CANCEL pad.
2. When oven has cooled to a safe temperature, door will unlock and can be opened. Do not force door open as damage can occur to door and lock.

Delayed Self-clean Cycle

Self-clean feature uses high oven temperature to clean oven interior. Set oven to begin and end cleaning at later time using. Range control calculates back from end time to determine starting time.

1. Prepare oven for self-cleaning.
 - Verify CONVECTION/STANDARD switch towards STANDARD and switch is not glowing.
2. Press CLEAN pad.
3. Press ▲ or ▼ pad until desired amount of cleaning time is displayed.
 - “3:00” displays when ▲ or ▼ is pressed.
 - Increase or decrease cleaning time in 5 minute increments.
 - Clean can be set from 2 to 4 hours. Minimum recommended cleaning time is 3 hours.
4. Press STOP TIME pad.
5. Press ▲ or ▼ pad until desired stopping time appears in display.
 - Starting time is automatically calculated based on amount of cleaning time and stop time.
 - “LOCK” flashes in display when automatic door latch is locking.
 - To view remaining cleaning time, press and hold CLEAN pad.
 - To view calculated stop time, press and hold STOP TIME pad.
 - When oven has cooled to a safe temperature, door latch opens and “LOCK” light flashes. When oven has cooled enough to open door “LOCK” light no longer displays and door can be opened.
 - When self-clean is finished, there will not be an end-of-cycle signal.

Interrupt Self-Clean Cycle

1. Press OVEN CANCEL pad.
2. When oven has cooled to a safe temperature, door will unlock and can be opened. Do not force door open as damage can occur to door and lock.



WARNING

To avoid risk of personal injury, do not touch oven vents or areas around vents during self-cleaning. These areas can become hot enough to cause burns.

To avoid risk of smoke damage or fire, clean excess spills from oven interior.



CAUTION

To avoid fire or smoke damage, remove any flammable materials from storage drawer. Items like plastic containers and paper manuals can melt or burn. Flammable materials should never be stored in the storage drawer.

- A small amount of smoke is normal when cleaning. Excess smoke may indicate a faulty gasket or too much food residue has been left in oven. **Move birds and small animals susceptible to fumes or smoke to another room.**
- Oven should be cleaned before it gets too dirty. Wipe up large spills before self-cleaning.
- Do not use cleaning cycle if oven light cover is not properly in place.
- Remove oven racks and all cooking utensils from oven.
- Clean excess spills from oven interior.
- Remove items from range top and backguard. These areas can become hot during self-cleaning cycle.
- Area around oven door and cavity will not self-clean since the high heat cannot reach this area.

Cooking Guide

Baking Guidelines

Follow these recommendations only as a guide for times and temperatures. Times, rack position, and temperatures may vary depending on conditions and food type. For best results, always check food at minimum time.

Food	Oven Temperature (°Fahrenheit)	Cooking Time (Minutes)
Angel Food Cake	350	28–50
Biscuits	350–375	8–16
Muffins	375–400	17–23
Cookies	325–350	7–18
Cupcakes	325–375	15–20
Brownies	325–350	25–35
Layer Cakes	325–350	20–30
Pound Cake	325	40–60
Fresh Pies	375–425	35–50
Nut Bread	350	45–55

Poultry Roasting Guidelines

Follow these recommendations only as a guide for times and temperatures. Times, rack position, and temperatures may vary depending on conditions and food type. For best results, always check food at minimum time.

Food	Oven temperature (°Fahrenheit)	Cooking time (Hours)
Whole Chicken (4 lbs to 5 lbs)	375	1½–1¾
Whole Chicken (Over 5 lbs)	375	1¾–2
Turkey (6 lbs to 8 lbs)	325	3½–4
Turkey (8 lbs to 12 lbs)	325	4–4½
Turkey (12 lbs to 16 lbs)	325	5½
Turkey (16 lbs to 20 lbs)	325	5½–7
Turkey (20 lbs to 22 lbs)	325	7–8½
Duck (3 lbs to 5 lbs)	325	1½–2

Beef and Pork Roasting Guidelines

Follow these recommendations only as a guide for times and temperatures. Times, rack position, and temperatures may vary depending on conditions and food type. For best results, always check food at minimum time.

Food	Oven Temperature (°Fahrenheit)	Cooking time (Minutes per pound)
Beef Roast (Rare)	325	20–25
Beef Roast (Medium)	325	26–30
Beef Roast (Well)	325	33–35
Rolled Roast (Rare)	325	32–36
Rolled Roast (Medium)	325	36–40
Rolled Roast (Well)	325	43–45
Fresh Whole Ham	325	22–28
Pork Loin	325	35–40
Pork Shoulder, Butt	325	40–45
Pork Picnic Shoulder	325	35–40
Mild Cured Ham Picnic, Shoulder	350	30–35

Broiling Guidelines

Follow these recommendations only as a guide for times and temperatures. Times, rack position, and temperatures may vary depending on conditions and food type. For best results, always check food at minimum time.

Food	Thickness (Doneness)	Rack position (1=Highest 5=Lowest)	Cooking time (Minutes)
Beef Steak	1" (med.)	3	14–16
Beef Steak	1" (well)	3	23
Beef Steak	1½" (med.)	3	23–28
Beef Steak	1½" (well)	3	33
Beef ground	(¾"–1")	4	12–17
Fish Fillets and Steaks		4	15–20
Pork Chops or Steak	1"	3	15–16
Pork Chops or Steak	1½"	3	23–28
Bacon		4	12–17
Ham Slice (pre-cooked)	½"	3	20–25
Ham Slice (pre-cooked)	1"	3	25–30

Cooking Guide (cont.)

Convection Baking Guidelines

Follow these recommendations only as a guide for times and temperatures. Times, rack position, and temperatures may vary depending on conditions and food type. For best results, always check food at minimum time.

Food	Oven Temperature (° Fahrenheit)	Cooking Time (Minutes)
Angel food cake	325	28–40
Biscuits	350–375	8–16
Muffins	375–400	15–23
Cookies	325–350	7–18
Cupcakes	325–375	15–20
Brownies	325–350	25–35
Layer cakes	325–350	20–30
Pound cake	325	40–60
Fresh pies	375–425	35–50
Nut Bread	350	45–55

Convection Broiling Guidelines

Follow these recommendations only as a guide for times and temperatures. Times, rack position, and temperatures may vary depending on conditions and food type. For best results, always check food at minimum time.

Food	Thickness (doneness)	Rack position (1=highest 5=lowest)	Cooking time (Minutes)
Beef ground	$\frac{3}{4}$ "–1"	4	9–15
Beef steaks	1" (med)	3	9–15
Beef steaks	1" (well)	3	16–18
Beef steaks	1½" (med)	3	18–20
Beef steaks	1½" (well)	3	20–25
Fish fillets and steaks		4	10–16
Pork chops or steaks	1"	3	12–14
Pork chops or steaks	1½"	3	15–20
Bacon		4	7–9
Ham slices (precooked)	$\frac{1}{2}$ "	3	10–15
Ham slices (precooked)	1"	3	15–18

Convection Poultry Roasting Guidelines

Follow these recommendations only as a guide for times and temperatures. Times, rack position, and temperatures may vary depending on conditions and food type. For best results, always check food at minimum time.

Food	Oven temperature (°Fahrenheit)	Cooking time (Hours)
Whole chicken (4 lbs to 5 lbs)	325	1½– 2
Whole chicken (Over 5 lbs)	325	2–2½
Turkey (6 lbs to 8 lbs)	275	3–3½
Turkey (8 lbs to 12 lbs)	275	3½–4½
Turkey (12 lbs to 16 lbs)	275	4½–5½
Turkey (16 lbs to 20 lbs)	275	5–7
Turkey (20 lbs to 22 lbs)	275	7–8
Duck (3 lbs to 5 lbs)	275	1–1½
Goose (6 lbs to 8 lbs)	275	1–1½

Convection Beef and Pork Roasting Guidelines

Follow these recommendations only as a guide for times and temperatures. Times, rack position, and temperatures may vary depending on conditions and food type. For best results, always check food at minimum time.

Food	Oven temperature (°Fahrenheit)	Cooking time (Minutes per pound)
Beef roast (rare)	275	15–20
Beef roast (medium)	275	25–30
Beef roast (well)	275	35–45
Rolled roast (rare)	275	20–25
Rolled roast (medium)	275	25–35
Rolled roast (well)	275	35–45
Fresh whole ham	275	20–25
Pork loin	275	30–35
Pork shoulder, butt	275	35–40
Pork picnic shoulder	275	30–35
Mild cured ham picnic shoulder	275	20–35

User Maintenance

Removing Oven Door

CAUTION

To avoid personal injury or property damage, handle oven door with care.

- Door is heavy and can be damaged if dropped.
- Do not lift door by handle.
- Avoid placing hands in hinge area when door is removed. Hinge can snap closed and pinch hands.
- Do not scratch or chip glass, or twist door. Glass may break suddenly.
- Replace door glass if damaged.

1. Open door fully.
2. Remove screws.
 - Oven doors are attached with a screw on each side of lower oven door.
3. Close door to first stop, grasp door firmly on each side, and lift upward until door is off hinges.
 - Do not lift door by handle. Glass can break.
 - Only push hinges closed after oven door is removed if necessary. Use both hands when closing hinge. Hinge snaps closed.

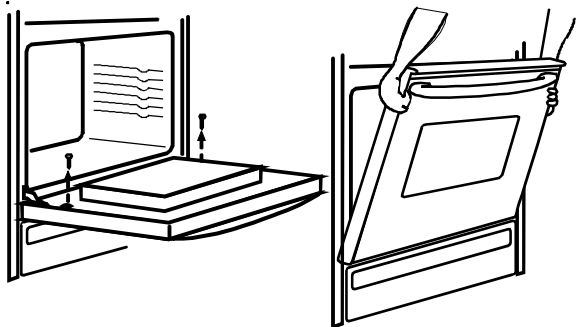

Removing Oven Door

Replacing Oven Light

WARNING

To avoid risk of burns or electrical shock, disconnect electrical supply to oven before changing light bulb.

- Wear gloves to protect hands from accidental bulb breakage.
- Before replacing light bulb make sure bulb is cool.
- Do not operate oven without bulb and cover in place.

1. Disconnect electrical supply.
2. Remove oven door if desired.
3. Unscrew light bulb cover located in rear of oven cavity. Then turn light bulb counterclockwise to remove.
4. Replace light bulb with 120-volt, 40-watt appliance bulb.
 - Do not overtighten bulb or it may be difficult to remove later.
5. Replace light bulb cover and oven door before use.
6. Reconnect power supply.

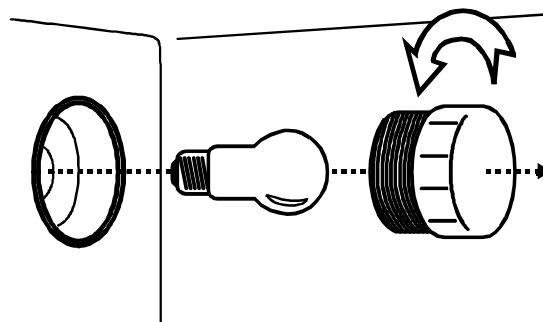

Removing Oven Light Bulb

Removing Storage Drawer (Some Models)

1. Slide drawer out until it stops.
2. Grasp drawer sides near back.
3. Lift up and out. Reverse to reinstall.

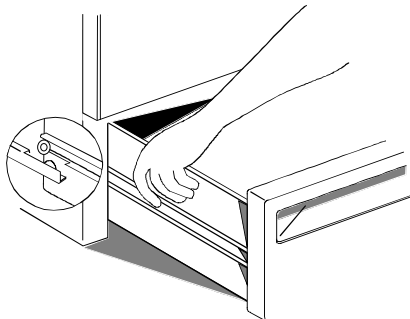

Removing Storage Drawer

Cleaning

Part	Materials to Use	General Directions
Bake and broil, element		Do not clean bake element or broil element. Any soil will burn off when element is heated. Bake element is hinged and can be lifted to clean oven bottom.
Broiler pan and grid	Soap and a nonabrasive plastic scouring pad	Drain fat, cool pan and grid slightly. (Do not let soiled pan and grid stand in oven to cool.) Sprinkle with soap. Fill the pan with warm water. Let pan and grid stand for a few minutes. Wash or scour if necessary. Rinse and dry. The broiler pan and grid may also be cleaned in the dishwasher.
Burner bowls	Soap and water	The burner bowls can be removed for ease in cleaning. For extra dried on soil, soak the bowls in warm soapy water.
Control knobs	Mild soap and water	Pull off knobs. Wash gently but do not soak. Dry and return controls to oven, making sure to match flat area on the knob to the flat area on shaft.
Smoothtop	Soap and water or smoothtop cleaner conditioner	Allow top to cool before cleaning. Wash surface with a dampened cloth and soapy water. For extra dried on soil, scrub surface with smoothtop cleaner conditioner available from an Amana Dealer. A single edge razor blade can be used to scrape off dried on soil. Do not use a harsh cleanser or steel wool pad. Metal markings should be cleaned after each use. If metal markings are allowed to remain on the top they will become increasingly difficult to remove.
Inside oven door	Soap and water	Clean the outside of the door and the window area with warm soapy water. Do not clean the oven door gasket. Gasket should not be moved while cleaning. Avoid getting any cleaning materials on gasket.
Outside finish and backguard	Soap and water	Wash all glass with cloth dampened in soapy water. Rinse and polish with a dry cloth. If knobs are removed, do not allow water to run down inside surface while cleaning.
Oven interior surfaces	Soap and water	Cool before cleaning. Frequent wiping with mild soap and water prolongs time between self-cleanings. Be sure to rinse thoroughly.
Oven racks and storage drawer	Soap and water	For heavy soil, clean by hand and rinse thoroughly. Remove the drawer and racks for ease in cleaning. Be sure drawer is dry before replacing.

Cleaning Smoothtop Rangetop

Problem	Cause	To Prevent	To Remove
Brown streaks and specks	Cleaning with a sponge or cloth containing soiled detergent water.	Use smoothtop cleaner conditioner with clean damp paper towel.	Use light application of smoothtop cleaner conditioner with clean damp paper towel.
Blackened, burned-on spots	Spatters or spillovers landing on a hot cooking area or accidental melting of plastic like a bread bag.	Wipe all spillovers when it is safe to touch cooking surface. Do not place plastic items on warm cooking area.	Clean area with smoothtop cleaner conditioner with clean damp paper towel, nonabrasive nylon pad, or scouring brush. If spot is not removed, allow cooktop to cool and carefully scrape area with a safety scraper held at a 30 degree angle.
Fine brown gray lines or fine scratches or abrasions which have collected soil	Course particles, like salt, become embedded in top if trapped under pan. Using abrasive cleaning materials. Scratches from rough ceramic, glass or ceramic-coated cookware.	Wipe bottom of cookware before cooking. Clean top daily with smoothtop cleaner conditioner with clean damp paper towel. Do not use ceramic or ceramic-coated cookware.	Fine scratches are not removable but can be minimized by daily use of smoothtop cleaner conditioner.
Smearing or streaking	Using too much smoothtop cleaner conditioner or using a soiled dish cloth.	Use small amounts of smoothtop cleaner conditioner. Rinse area thoroughly before drying. Use only clean damp paper towel, nonabrasive nylon pad, or scouring brush.	
Metal or silver/gray marks	Sliding or scraping metal utensils across top.	Do not slide metal objects across top.	Remove marks before top is used again. After top cools, clean marks with smoothtop cleaner conditioner with clean damp paper towel, nonabrasive nylon pad, scouring brush, or scrape gently with safety scraper.. Rinse thoroughly and dry.
Pitting or flaking	Boilovers of sugar syrup on a hot rangetop can cause pitting if not removed immediately.	Watch sugar and syrups carefully to avoid boilovers.	Turn control to <i>LO</i> setting. Using several paper towels. Allow top to cool and carefully scrape area with a safety scraper held at a 30 degree angle.
Hard water spots	Condensation from cooking can cause minerals found in water and acids in food to drip onto rangetop and cause gray deposits. Spots are often so thin they appear to be in or under rangetop.	Make sure bottom of cookware is dry before cooking. Daily use of smoothtop cleaner conditioner helps keep top free of hard water, mineral deposits and food discoloration.	Mix smoothtop cleaner conditioner with water and apply thick paste to stained area. Scrub vigorously. If stain is not removed, reapply cleaner and repeat process. Also try cleaning process for "Smearing and streaking".

Before Calling for Service

Problem	Check
Oven light does work.	Check for loose bulb. Check for burned out bulb; replace with 40-watt appliance bulb.
Oven does not heat.	Confirm range is plugged in. If both oven and surface elements do not heat, check circuit breaker. Check control for proper setting.
Oven door will not open.	Wait for oven to cool. Door latch will release automatically after oven cools. Do not force door open.
Oven temperature is not accurate.	Store purchased oven thermometers do not measure oven temperature accurately. An accurate digital thermometer is necessary to calibrate oven. Check for blocked heat vents. Aluminum foil alters oven temperature. Change oven temperature through oven control: <ol style="list-style-type: none"> 1. Push BAKE pad. 2. Push up or down arrow pad until an oven temperature more than 500°F shows. 3. Immediately push and hold BAKE pad until "00" shows (approx. 5 seconds). 4. To decrease oven temperature (for a cooler oven), Push down arrow pad until negative numbers appear. Oven can be adjusted from -05° to -35° lower. To avoid over adjusting oven move temperature -5° each time. 5. To increase oven temperature (for a warmer oven), Push up arrow pad until positive numbers appear. Oven can be adjusted from 5° to 35° higher. To avoid over adjusting oven move temperature 5° each time. 6. Push OVEN CANCEL button. Temperature adjustment will be retained even through a power failure.
Oven element cycles on and off.	This condition is normal when baking or roasting. To maintain a temperature for baking, oven cycles on and off. The temperature may vary up to 25°F higher or lower than the oven temperature set on the control.
Oven smokes the first few times used.	Minor smoking is normal first few times oven is used.
Odor or smoke while self-cleaning the oven.	There may be some smoke and odor during the first few cleaning cycles. If there is excessive smoke or odor, too much soil remains in the bottom of the oven. If the oven smokes excessively, turn off the oven, wait for oven to cool and wipe away excess soil. Reset the clean cycle.
Smoothtop element cycles on and off.	Normal condition.
Range top is warm during use .	Normal condition.
Food cooks slowly or will not maintain constant boil.	Improper cookware causes poor cooking results. Pan bottoms must be flat. Pans should be made of heavy material and be same diameter as surface element. See "Utensil Recommendations" section.
Indicator light(s) remain on after smoothtop surface element is turned off.	This is normal. Indicator light(s) will remain on until range surface cools.

Warranty

COOKING PRODUCTS WARRANTY

(excluding wall ovens)

**FULL ONE YEAR WARRANTY
LIMITED SECOND YEAR WARRANTY ON ALL PARTS
LIMITED THIRD THRU FIFTH YEAR WARRANTY ON GLASS/CERAMIC TOP,
ELECTRIC SURFACE ELEMENTS, OR GAS SURFACE BURNERS.**

FIRST YEAR

Caloric Sales Co. L.P. will repair or replace, including related labor and travel, any part (FOB Amana Iowa) which proves to be defective as to workmanship or materials.

SECOND YEAR

Caloric Sales Co. L.P. will provide replacement part, part only (FOB Amana Iowa), which proves defective as to workmanship or materials.

THIRD THROUGH FIFTH YEAR

Caloric Sales Co. L.P. will provide replacement glass/ceramic cooktop, electric surface elements or gas surface burners, part only (FOB Amana Iowa) which prove defective as to workmanship or materials.

OWNER'S RESPONSIBILITIES:

- Provide any defective part to an authorized Caloric Sales Co. L.P. servicer.
- Provide proof of purchase.
- Provide normal care and maintenance, including cleaning as instructed in owner's manual.
- Replace owner replaceable items where directions appear in the owner's manual.
- Make product accessible for service.
- Pay for premium service costs for service outside servicer's normal business hours.
- Pay for service calls related to product installation and customer education.

ITEMS NOT COVERED:

- Normal product maintenance and cleaning.
- Light bulbs.
- Damages which occur in shipment.
- General rebuilding or refurbishing that is not a legitimate warranty repair.
- Failures caused by:
 - Unauthorized service.
 - Grease or other material buildup due to improper cleaning or maintenance.
 - Accidental or intentional damage.
 - Connection to an improper gas or power supply.
 - Accident, misuse, abuse, fire, flood, or acts of nature.
 - Use of improper pans, containers, or accessories that cause damage to the product.

WARRANTY LIMITATIONS:

- Begins at date of original purchase.
- Product used on a commercial, rental, or leased basis are not covered by this warranty.
- Applies to product used within the United States or in Canada if product has appropriate agency listing when shipped from the factory.
- Service must be performed by an authorized Caloric Sales Co. L.P. servicer.

WARRANTY IS VOID IF:

- Serial plate is defaced.
- Product is altered by user.
- Product is not installed or used according to manufacturer's instructions.

IN NO EVENT SHALL CALORIC SALES CO. L.P. BE LIABLE FOR INCIDENTAL OR CONSEQUENTIAL DAMAGES*

*This warranty gives you specific legal rights and you may have others which vary from state to state. For example, some states do not allow the exclusion or limitation of incidental or consequential damages so this exclusion may not apply to you.

For answers to questions regarding the above or to locate an authorized Caloric Sales Co. L.P. servicer, contact:

Caloric Sales Co. L.P.
2800 220th Trail
PO Box 8901
Amana, Iowa 52204-0001
USA
1-800-843-0304 inside U.S.A.
1-319-622-5511 outside U.S.A.